

RESOL DeltaSol® A

Mounting

Connection

Operation

Examples



reddot design award
winner 2005



48000190

Thanks for buying a RESOL controller.
Read this manual carefully to get the best performance from this unit.

DeltaSol® A



Manual

www.resol.de

Contents

Imprint	2	2. Adjustments and commissioning.....	5
Security devices.....	2	3. Anti-freeze function.....	5
Technical data and function survey	3	4. Blinking codes.....	5
1. Installation	4	5. Tips for fault diagnostics.....	5
1.1 Mounting.....	4	6. Application examples.....	6
1.2 Electrical connection	4	Annex: Fault diagnostics.....	8

Safety regulations:

Please read the following information carefully before installing and operating the controller. In this way damage to the solar system by wrong installation will be avoided. Please observe that the mounting is adapted to the characteristics of the building, that the local regulations are respected and is conform to the technical rules.

DIN 4757, part 1

Solar heating systems with water and water mixtures as heat transfer medium; Demands to the safety realization.

DIN 4757, part 2

Solar heating systems with organic heat transfer medium; Demands to safety realization.

DIN 4757, part 3

Solar heating systems; solar collectors; Meanings; safety regulations; Testing of standstill temperature

DIN 4757, part 4

Solar thermal systems; solar collectors; determination of efficiency, heat capacity and pressure loss.

In addition to that European standards are worked out:

PrEN 12975-1

Thermal solar systems and their components; collectors, part 1: General demands.

PrEN 12975-2

Thermal solar systems and their components; collectors; part 2: Test processes

PrEN 12976-1

Thermal solar systems and their components; prefabricated systems, part 1: General demands.

PrEN 12976-2

Thermal solar systems and their components; prefabricated systems, part 2: Test processes

PrEN 12977-1

Thermal solar systems and their components; Customer-designed manufactured systems, part 1: General demands.

PrEN 12977-2

Thermal solar systems and their components; Customer-designed manufactured systems, part 2: Test processes

PrEN 12977-3

Thermal solar systems and their components; Customer-designed manufactured systems, part 3: Performance test of warm water stores.

This mounting- and operation manual including all parts is copyrighted. Another use outside the copyright requires the approval of RESOL - Elektronische Regelungen GmbH. This especially applies for copies, translations, micro films and the storage into electronic systems.

Editor: RESOL - Elektronische Regelungen GmbH

Important notice:

We took a lot of care over the texts and drawings of this manual and to the best of our knowledge and consent. As faults can never be excluded, please note:

Your own calculations and plans under consideration of the current norms and DIN-directions should only be basis for your projects. We don't offer a guarantee for the completeness of the drawings and texts of this manual - they only represent some examples. They can only be used on own risk. No liability is assumed for incorrect, incomplete or false information and the resulting damages.

Errors and technical changes excepted.

Scope of delivery:

- controller *DeltaSol® A* (full kit incl. 2 temperature sensors)
- spare fuse under cover
- accessory bag consisting of silicone sealing, fastening screws and dowels, strain relief clamp and screws
- manual

Technical data**Housing:**

plug-in plastic PC-ABS

Protection type: IP 20 / DIN 40050**Ambient temp.:** 0 ... 40 °C**Size:** Ø130 mm, 45 mm height**Mounting:** wall mounting**Display:** 1 function control lamp**Inputs:** 2 sensor inputs PT1000**Outputs:** 1 standard relay (changeover contact)**Switch-on difference:** ΔT 2 ... 16 K adjustable**Switch-off difference:**

1,6 K below switch-on difference

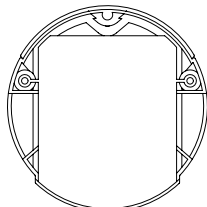
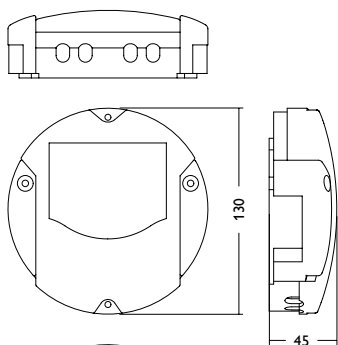
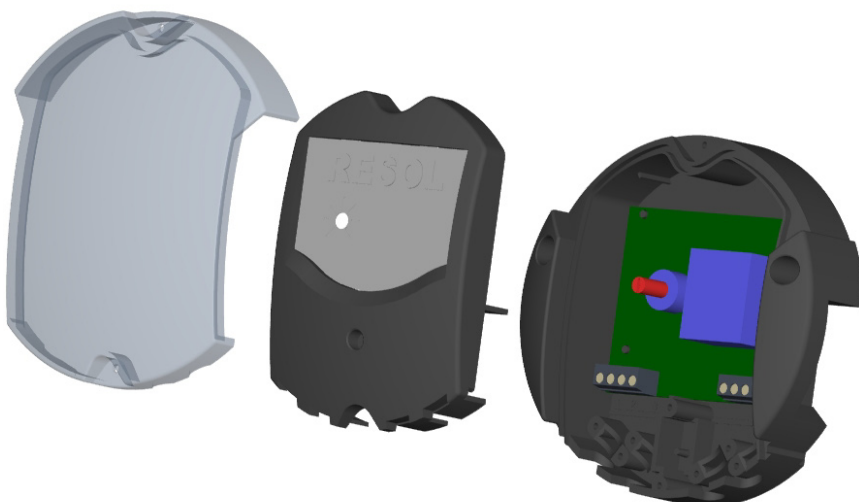
Control range: -20 ... +150 °C**Power consumption:** max. 4A**Powersupply:** 220 ... 240V~**DeltaSol® A**

Due to the tough and consciously simple designed concept for the controller **DeltaSol® A**, this low-priced differential controller can be universally used in solar-, heating- and air conditioning systems. The huge control range and the adjustable temperature difference make an application in nearly all systems possible in which switching processes are realised by temperature differences.

The housing is optionally available with a sealing, which protects the electronics against dripping water (IP22).

The controller checks a temperature difference ΔT measured by one of two temperature sensors by comparing this difference with a preadjusted temperature difference (adjustable within the range of 2 ... 16 K). The control of the system is effected by a standard relay (= changeover contact), to which several motors or electrical valves can be connected. The controller switches- ON, if the adjusted temperature difference is exceeded; if this difference is underrun by 1,6 K, the controller switches-OFF.

Order indications

RESOL DeltaSol A **115 211 20**

RESOL DeltaSol A - full kit - **115 211 30**
incl. 2 temperature sensors Pt1000 (1 x FKP6, 1 x FRP6)

Accessory**Overvoltage protection**

It is highly recommended to connect the RESOL overvoltage protection SP1 to all collector sensors in order to avoid overvoltages (e.g. by lightning).

RESOL SP1 **180 110 10**



Electrostatical discharges can lead to damages of electronic components!



Dangerous voltage on contact!



1. Installation

1.1 Mounting

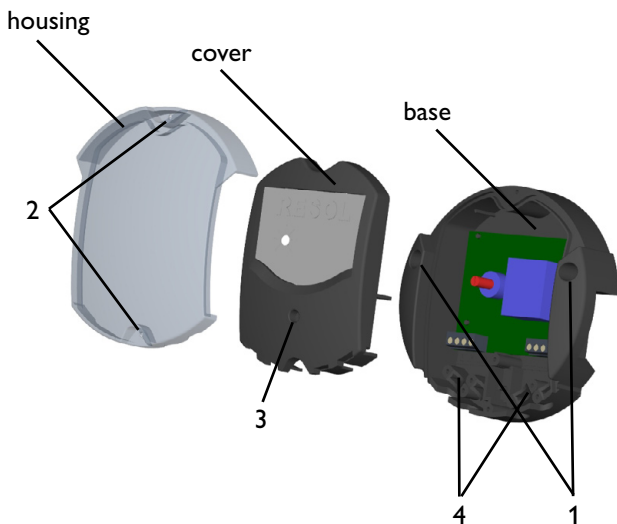

Warning!
Switch-off power supply before opening the housing.

The unit must only be located internally. It is not suitable for installation in hazardous locations and should not be sited near to any electromagnetic field. Please pay attention to a separate laying of the cable lines and installation of ac power supply.

1. Choose a mounting place, drill two holes of Ø 6 mm side by side with a distance of 113 mm and fit in the enclosed dowels.
2. Fix the controller by means of the enclosed screws (4 x 40 mm)(pos. 1).
3. The electrical connection must be effected now. Power supply of the controller (220 ... 240 V) must be effected by external power switch.

1.2 Electrical connection

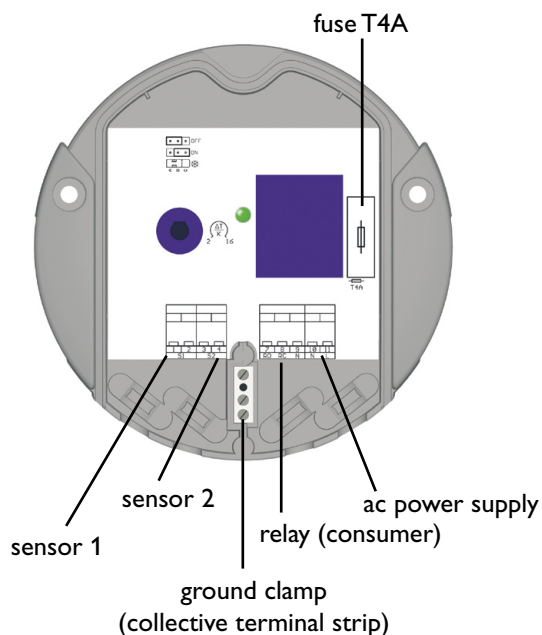

Connection of the sensors at the clamps:

- 1 / 2 = sensor 1 (e.g. collector sensor)
- 3 / 4 = sensor 2 (e.g. store sensor)

Connection of the consumer to the clamps:

- 7 = normally open contact relay (RO)
- 8 = break contact relay (RC)
- 9 = neutral contact relay (N)
- ground clamp \oplus collective terminal strip

ac power supply to the clamps:

- 10 = neutral conductor N
- 11 = conductor L
- ground clamp \oplus (**collective terminal strip**)

The guides of the required insertion channels must be broken away at the bottom side of the cover.

The lines are to be fixed to the housing by enclosed strain relief supports and screws (pos.2).

If necessary, activate anti-freeze function by jumper. Insert enclosed silicone sealing in base nut (without strain), if dripping water protection is necessary.

Put on the cover and screw it (pos. 3). If necessary, adjust temperature difference ΔT .

Put on housing cover and screw it (pos. 4).

Insert sealing band without strain into the nut

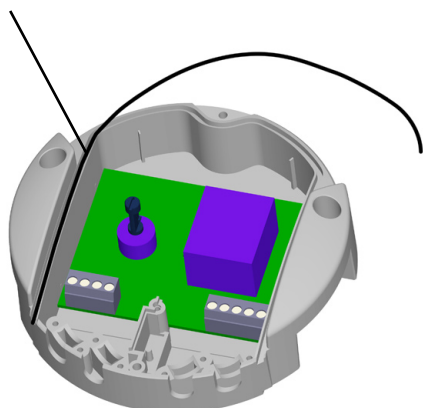

2. Adjustments and commissioning

operating control lamp

potentiometer for temperature difference



Before closing the housing, the specific temperature difference ΔT must be adjusted at the potentiometer within a scale of 2K...16K. In practice, values between 6K...8K have proved.

The controller comes with a switch-off delay (hysteresis) adjusted by RESOL to 1,6 K and cannot be changed.

The controller switches over the relay if the temperature difference between the sensors S1 and S2 is reached or exceeded. The controller switches the relay back, if the adjusted temperature difference is again underrun by 1,6 K.

3. Anti-freeze function

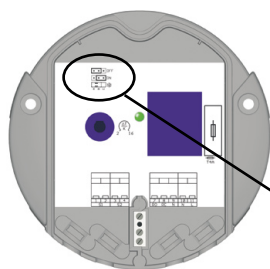

The controller comes with a deactivated anti-freeze function (by RESOL.)

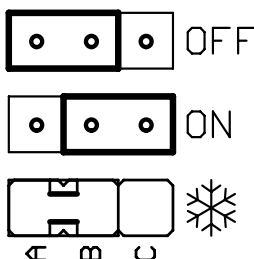

The controller RESOL DeltaSol® A is equipped with anti-freeze function. Solar systems are normally run with a glycol-water mixture. Due to the chemical features of this mixture an additional anti-freeze protection is not necessary. But in some cases, solar systems are only operated with water. The anti-freeze function responds to the temperature of sensor S1 (collector sensor). As soon as this sensor measures a temperature below +4 °C, warmer water from the store is pumped into the collector in order to avoid damages at the collector. If a temperature of +5 °C is reached at S1, the pump switches-off.

Please note that due to the limited „heat reserve“ of the store, this function is only appropriated for those regions in which temperatures around freezing point are only reached few days per year.

The jumper must be set to the position marked correspondingly in order to activate (on) or deactivate (off) the anti-freeze function.

4. Blinking codes

relais actif	vert
Fonction antigel	dignotant vert

The LED shows the actual operating status of the controller.

5. Tips for fault diagnostics



bracket for spare fuse (interior part of cover)

If the controller does not work perfectly, please check the following items:

If the controller does not switch-on correctly, even if ac power supply is impressed, please check the fuses (see 1.2). The controller is guarded by a fine fuse T4A, which can be replaced after having removed the housing and the cover. A spare fuse is enclosed on the backside of the cover.

Please check the sensors. Sensors which are not connected, must have the following resistance values depending on the given temperature.

°C	-10	-5	0	5	10	15	20	25	30
Ω	961	980	1000	1019	1039	1058	1078	1097	1117
°C	35	40	45	50	55	60	65	70	75
Ω	1136	1155	1175	1194	1213	1232	1252	1271	1290
°C	80	85	90	95	100	105	110	115	
Ω	1309	1328	1347	1366	1385	1404	1423	1442	

Resistance values of Pt1000-sensors

6. Application examples

Standard solar system with 1 store

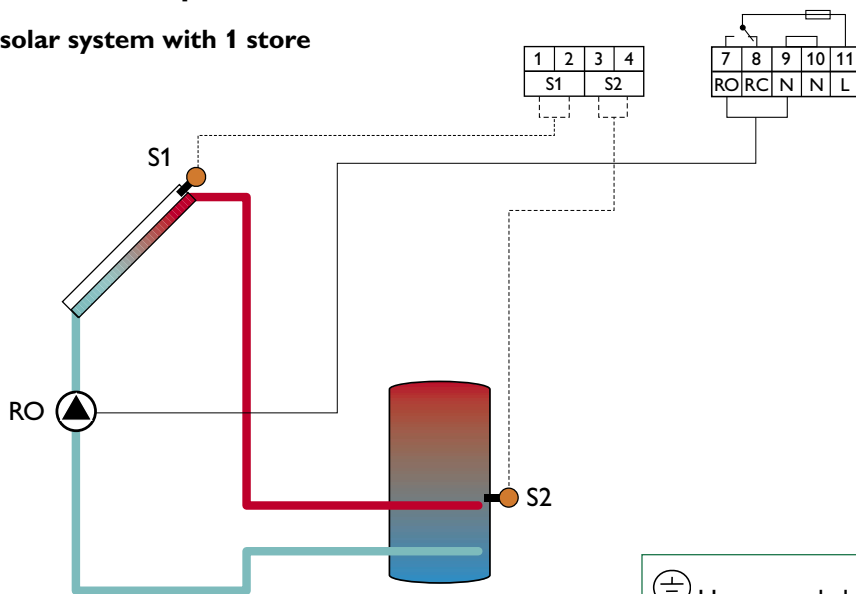

If the current temperature difference ΔT between collector sensor S1 and store sensor S2 exceeds the temperature difference adjusted at the controller, the solar pump is switched-on. Heat is transported from the collector to the store; in doing so, the temperature difference is reduced. If the adjusted temperature difference is underrun by a difference

of 1,6 K (hysteresis, cannot be changed), the pump is switched-off again.

- S1 = collector sensor
- S2 = store sensor
- RO = solar pump

Heating circuit reverse raising

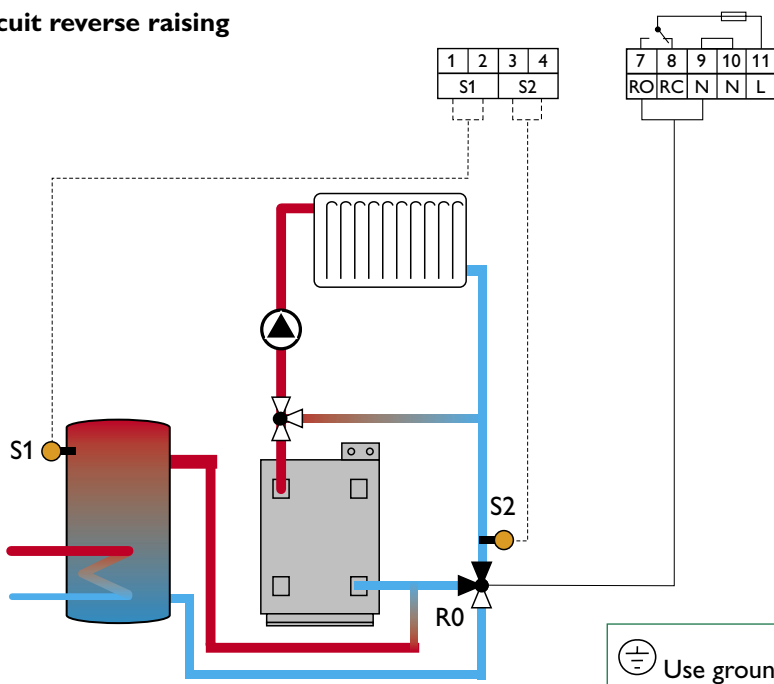



If the temperature difference ΔT between store sensor S1 and heating circuit reverse sensor S2 exceeds the temperature difference adjusted at the controller, the 3-way-valve is switched-over. The reverse temperature of the heating circuit is raised by the heat of the store so that less conventional energy is necessary for reaching the feed flow temperature; in doing so, the temperature difference is

reduced. If the adjusted temperature difference is underrun by a difference of 1,6 K (hysteresis, cannot be changed), the valve is switched to initial position.

- S1 = store sensor
- S2 = heating circuit reverse sensor
- RO = 3-way-valve

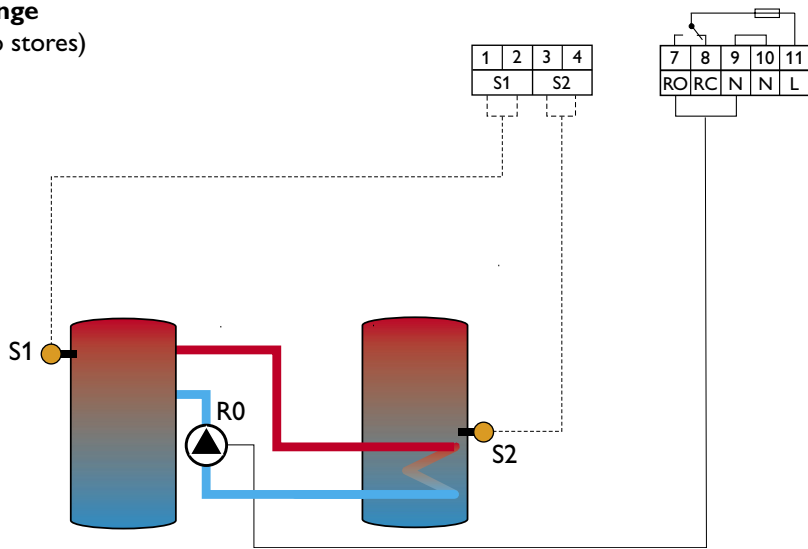
Heat exchange
(between two stores)



 Use ground clamp collective terminal strip!

If the temperature difference ΔT between store (1) sensor S1 and store (2) sensor S2 exceeds the temperature adjusted at the controller, the circulation pump is switched-on. Heat is transported from the store (1) into store (2); in doing so, the temperature difference is reduced. If the adjusted

temperature difference is underrun by a difference of 1,6 K (hysteresis, cannot be changed), the pump is switched-off again.

- S1 = store (1) sensor
- S2 = store (2) sensor
- RO = circulation pump

Annex: Fault diagnostics

Pump is overheated, but no heat transfer from collector to the store, feed flow and return flow are equally warm, perhaps also bubble in the lines.

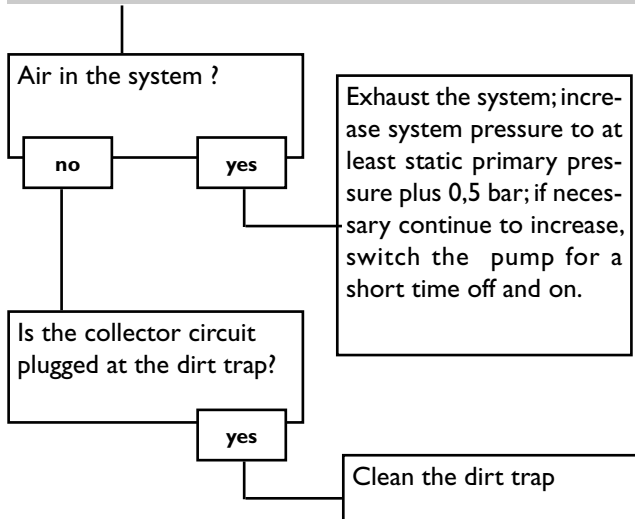

Pump starts for a short moment, switches-off, switches-on again, etc. („controller hunting“)

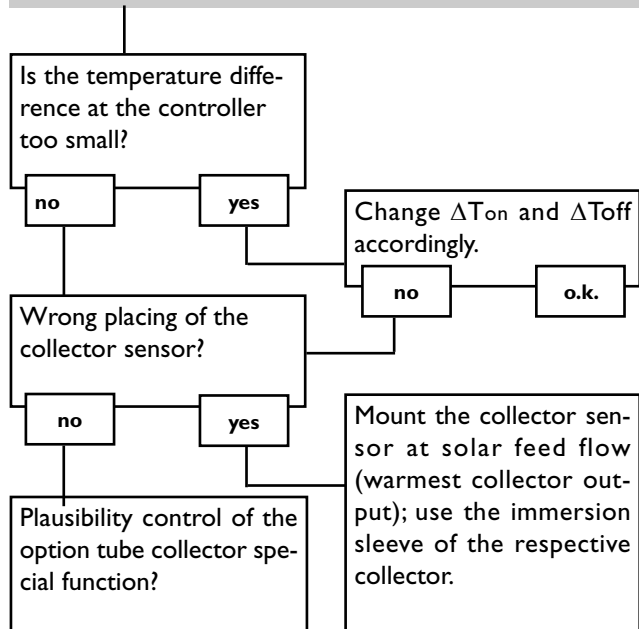

Pump starts up very late and soon stops working soon.

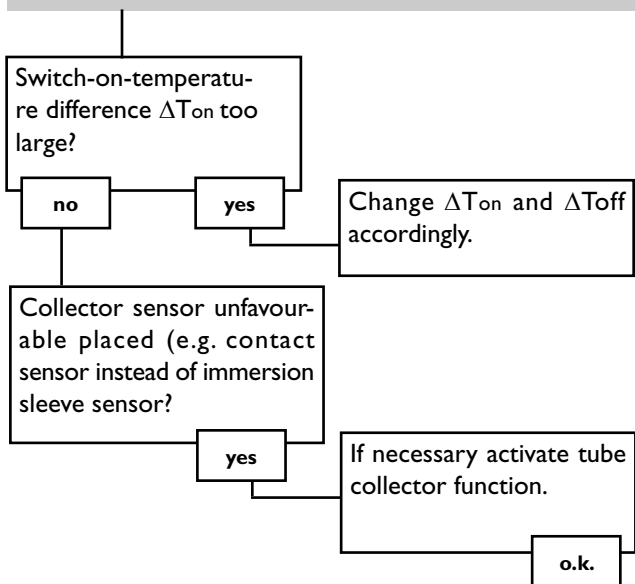

The temperature difference between store and collector increases enormously during operation; the collector circuit cannot dissipate the heat.

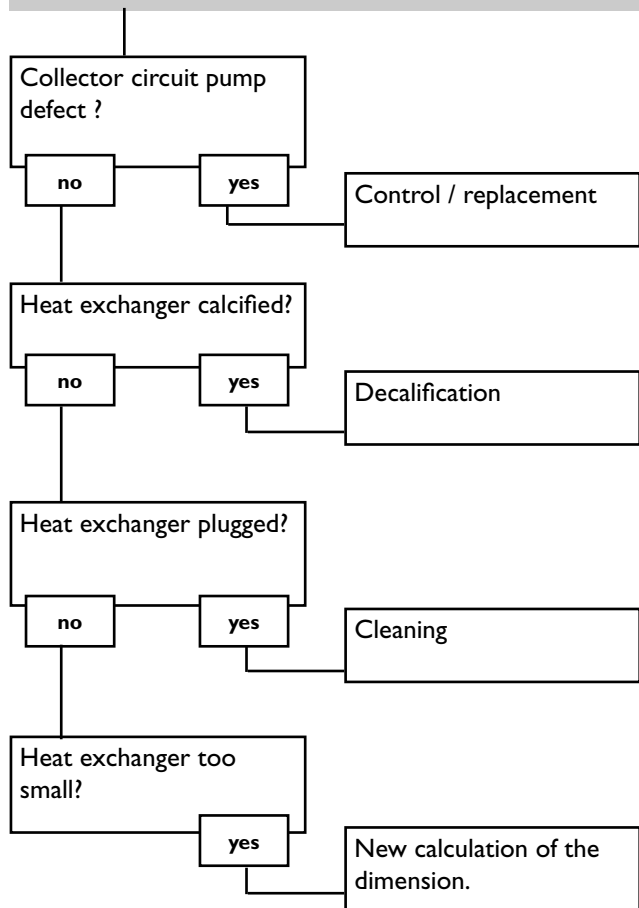

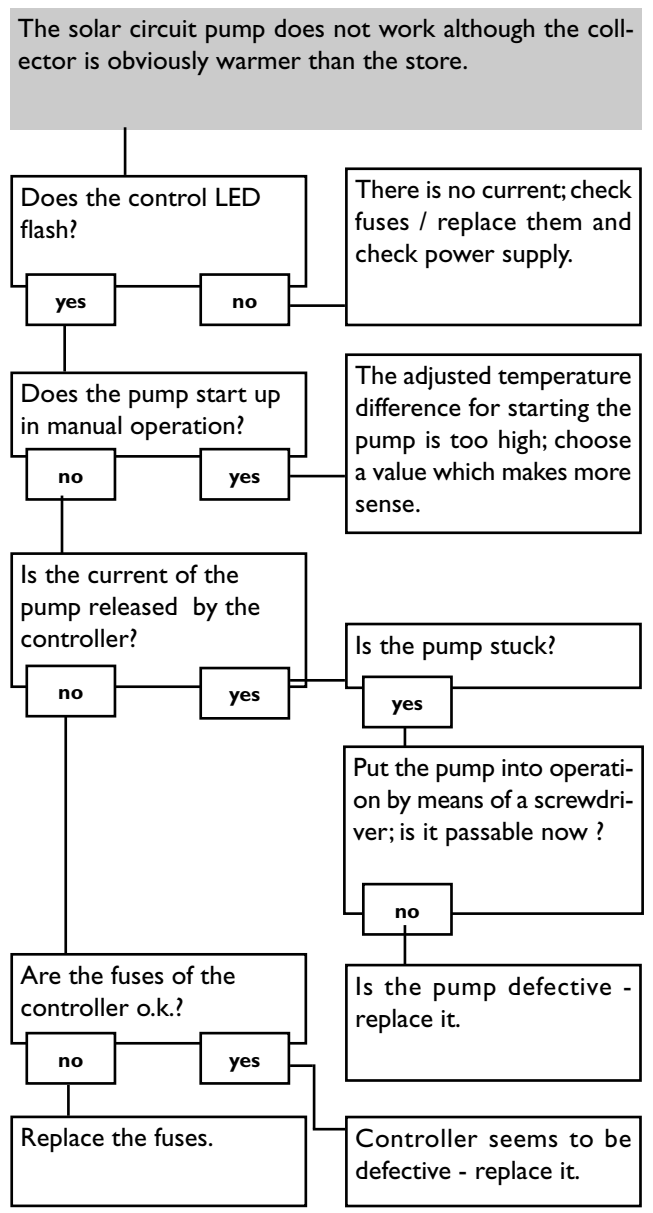
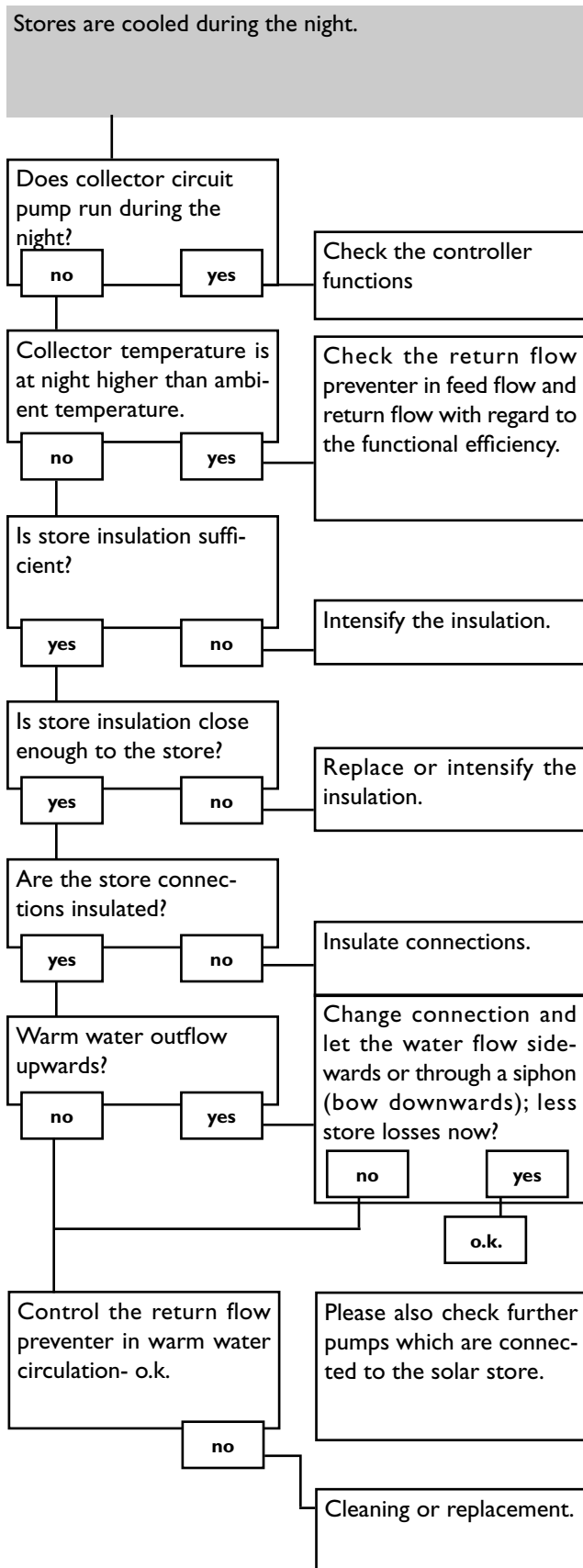

Notes

Notes

Empty rectangular area for notes.

RESOL - Elektronische Regelungen GmbH

Heiskampstraße 10
D - 45527 Hattingen

Tel.: +49 (0) 23 24 / 96 48 - 0
Fax: +49 (0) 23 24 / 96 48 - 55

www.resol.de
info@resol.de

Your wholesaler:



Please note:

The design and the specifications are to be changed without notice.
The illustrations may differ from original product.