

# FlowCon S

**Installation**

**Operation**

**Commissioning**



# FlowCon S



**Manual**



48001120

**Thank you for buying FlowCon S.  
Read this manual carefully to get the best performance from this unit.**

**Contents:**

<b>Imprint .....</b>	<b>2</b>	<b>2. Filling and flushing of the system.....</b>	<b>5</b>
<b>Security advice .....</b>	<b>2</b>	<b>3. Emptying the system .....</b>	<b>6</b>
<b>Technical data and functional survey .....</b>	<b>3</b>	<b>4. Non-return valves.....</b>	<b>6</b>
<b>1. Installation.....</b>	<b>4</b>	<b>5. Security device.....</b>	<b>6</b>
<b>1.1 Mounting of the solar group.....</b>	<b>4</b>		
<b>1.2 Mounting of the pipes into a cutting ring connection .....</b>	<b>5</b>		

**Imprint:**

This mounting- and operation manual including all parts is copyrighted. Any use outside the copyright requires the approval of RESOL - Elektronische Regelungen GmbH. This especially applies for copies, translations, micro films and the storage into electronic systems.

RESOL - Elektronische Regelungen GmbH

**Important notice:**

We took a lot of care over the text and drawings in this manual and to the best of our knowledge and belief. As faults can never be excluded, please note:

Your own calculations and plans under consideration of the current norms and DIN-directions should only be used for your projects. We don't offer a guarantee for the completeness of the drawings and texts of this manual - they only represent some examples. They can only be used at your own risk. No liability is assumed for incorrect, incomplete or false information and the resulting damage.

Errors and technical changes excepted.

**Security advice:**

- Mounting and installation of solar systems underlie DIN EN 12976-1.
- The expansion vessel must be checked regularly according DIN 4807.
- Solar systems are to be grounded technically against lightnings.
- Electronical connections must only be done by qualified personnel. Corresponding instructions (VDE 0100, VDE 0185, VDE 0190 etc.) are to be considered as well as particular local (building) regulations.

**Solar station with integrated controller**

Prepared for integration of the controller:  
Vega 1, Vega 2

- Dial thermometer for feed flow
- Outstanding design
- Security device with safety valve and manometer
- Filling and emptying unit
- Wall mounting with screws and dowels
- Heat insulation

**Technical data:****Material:**

fittings: bras

flat sealings: Klingerit, max. 200 °C

O-ring-seal: VITON / EPDM,  
max. 180 °C

Solar non-return valve: PPS,  
max. 180 °C

Insulation: EPP, max. 120 °C, at short  
term to 180 °C

**Adm. max. temp.:**

0 ... 120 °C, at short term to 180 °C

**Size:**

with insulation: 500x230x62 mm  
distance axis / wall: 62 mm

**Mounting:** wall mounting

**Connections:** 3/4" IG

**Circulation pump:** WILO Star  
ST20/6 or ST 20/7 (additional charge)

**Power supply:**  
220 ... 240V~

**Operation pressure:** max. 8 bar

**Spring pressure of non-return  
valve:** 200 mm water column

**Flowmeter:** 0,5...5 l/min,  
1...13 l/min (standart) or  
8...30 l/min



Electrostatic discharge can  
lead to damages of  
electronic components!



Dangerous voltage on  
contact



1. Installation

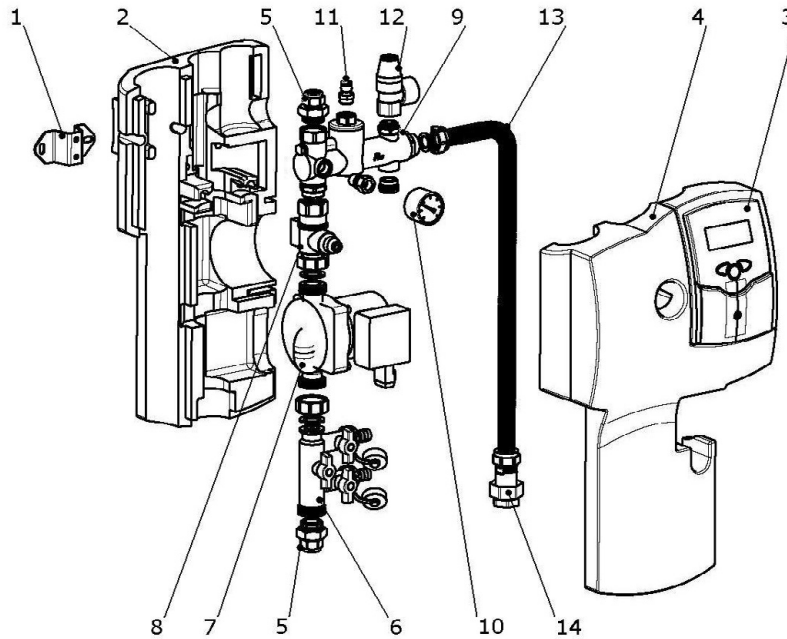

- |   |   |
|---|---|
| 1 wall mounting                               | 9 security-head piece with fill-cock (KFE-cock) |
| 2 insulation - backside                       | 10 solar manometer 0...6 bar                    |
| 3 controller                                  | 11 solar manual discharge                       |
| 4 insulation - forepart                       | 12 solar security valve 6 bar                   |
| 5 flowmeter                                   | 13 stainless steel corrugated tube 3/4" IG      |
| 6 flushing-cock (KFE-cock)                    | 14 solar expansion vessel clutch                |
| 7 pump  |   |
| 8 ball valve with integrated non-return valve |   |

1.1 Mounting of the solar station

- Determine mounting place.
- Unpack the whole solar station.
- Take off the front insulation jacket of the solar station. **Have the solar group always screwed to the backside of the insulation jacket!**
- Mark the bore holes through the insulation, drill with a 8 mm drill, put the enclosed dowels (S8) into the bore holes.
- Fasten the complet solar group with the enclosed screws (S6 x 60 mm) to the wall. Use therefor a positive cross recess screw-driver!
- Establish the pipework between the solar group and the store and collector respectively.

All the connections are checked and tightened so that normally a retightening is not necessary. However by commissioning of the system all the connections have to be checked at tightness (pressure test).

**The following instructions have to be considered urgently for connection of the pipes into the cutting ring!**

## 1.2 Mounting pipes into a cutting ring connection

- At first, slide over the copper pipe (1), the connecting nut (2), then the compression ring (3). To assure that there is a save force transmission and sealing the pipe has to stand out of the compression ring for aprox. 3 mm.
- Slide the copper pipe (1) into the support sleeve (4).
- The copper pipe (1) with its slipped-on components (2;3;4) has to be pushed as far as it will go into the housing of the cutting ring connection (5).
- Firstly the connecting nut has to be tightened by hand. Afterwards use a flat spanner to turn the connecting nut at least one rotation.

### Please note:

In order to absorb the expansion pressure of the pipes, the relevant fittings (expansion bushings) or pipe-level (consisting of more than two 90° bows) are necessary.

For pipe-levels the space between the bows has to be twice than the diameter of the pipe in cm.

[Example: diameter of the pipe = 18 mm; space between the bows more than 36 cm].

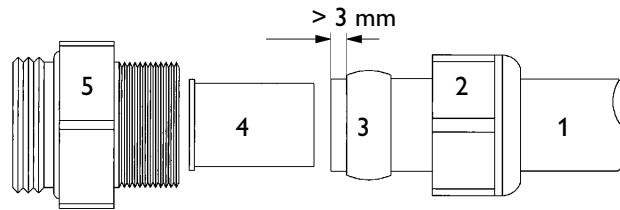

## 2. Filling and flushing the system

- Connect flexible pressure tubes to the KFE-cock below the manometer and open the cock.
- Connect the flexible tube to the KFE-cock for flushing and open the cock afterwards.
- The slit of the regulating screw at the flowmeter has to be adjusted horizontally. Thus the integrated ball valve is closed (see manual flowmeter). Open the non-return valve above the pump; therefore adjust the ball valve by means of a combination- or flat-wrench in position of 45° (half opened, half closed).
- Fill sufficient solar fluid into a canister of a filling station (not included in full kit) and fill the solar system.
- By means of the filling station flush the solar system at least 15 minutes. To get the air completely out of the system, it is necessary to open the regulation screw at the flowmeter (slit vertical) temporary in between.
- The complete solar system must not be flushed with water. As a total emptying of the system is not possible mostly, there is a danger of frost damage.
- Close the KFE-cock (outflow cock) while the filling pump is running and increase the system pressure to aprox. 6 bar. The system pressure can be read off at the manometer.
- Close the filling cock and switch-off the pump of the filling cock, open the regulation screw (slit vertical).
- Bleed the system above the collector until the solar fluid is free of blow holes. Increase the testing pressure to aprox. 6 bar again and check the thickness of the system. In case of dramatically decrease of pressure one has an untight location in the system is to assume.
- Adjust the system pressure according to the general instructions of the system manufacturer (possibly aprox. 1,8 to 2,3 bar with a height of the collector above the manometer of aprox. 5 to 10 m, thereby observe the primary pressure of the expansion vessel).
- Start the circulation pump with its maximum pump speed (see manual of the circulation pump) and let it pump for at least 15 minutes.
- Afterwards adjust the pump speed to the favoured pump speed.
- Adjust the volume flow at the flowmeter according to the general instructions of the collector's manufacturer.
- Remove the tube of the filling station and screw the catch to the filling station's cocks.
- Recheck the system again for thinkness. Open the ball valve above the pump completely.
- Mount the front insulation jacket to the solar group.

**3. Emptying of the system**

- Open the non-return valve in the ball valve (therefore see following advice).
- Open the exhauster at the highest point of the system (above the collector).

- Open the KFE-cock at the lowest point of the system, if possible close by the store connection (not included in the full kit) and the pump.

**4. Non-return valve**

- The non-return valve of the solar group is integrated into the ball valve above the circulation pump. It has an opening pressure of 200 mm water column.
- To empty the system completely, the non-return valve has to be opened. Therefore the knob of the ball valve has to be **in position of 45°**. In doing so, the ball in the ball valve opens the non-return valve.
- In normal operation of the system, the ball valve has to be completely opened .
- In order that wrong circulation can be avoided (as well as “In-pipe-circulation“) the flow line (from the collector to the store) has to be equipped with a siphon or an additional non-return valve.

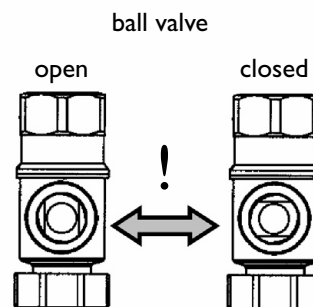
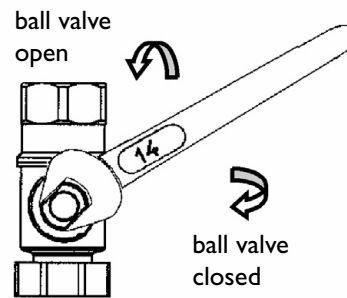

**5. Security device**

- The solar station is prepared with a solar-diaphragm security valve, which corresponds to relevant rules and regulations. The following references have to be considered during the installation and operation of the solar station:
- The security valve has to be available. The efficiency of the valve must not be influenced or disabled by barriers!
- The dirt trap or other strictures are inadmissible between the collector (-field) and the security valve!
- The diameter of the pipe must correspond to the diameter of the valve exit; the maximum length must not be longer than 2 m; more than 2 bows are inadmissible. By overstepping the maximum values (2 bows, 2 m pipe), you have to install a blow off pipe in larger dimensions. However, it has to be considered that more than 3 bows and 4 m pipe length is inadmissible.
- If the blow-off pipe leads into a drain pipe with a hopper,

the size of the drain pipe has to be at least twice as big as the valve's inflow. in addition to that, the blow-off pipe must be installed gradiently; the mouthpiece has to be open and observable and routed in that way of blowing off no persons are endangered.

- It is useful to place a canister under the blow off pipe. In case that the security valve opens the fluid is caught and it can be refilled in case of lower system pressure.

Notes:

---

**RESOL - Elektronische Regelungen GmbH**

Heiskampstraße 10  
D - 45527 Hattingen

Tel.: +49 (0) 23 24 / 96 48 - 0  
Fax: +49 (0) 23 24 / 96 48 - 55

[www.resol.de](http://www.resol.de)  
[info@resol.de](mailto:info@resol.de)

**Your specialist dealer:**



**Please note:**

**The design and the specifications are to be changed without notice.  
The illustrations may differ from original product.**