

# FriWa

**Mounting**

**Connection**

**Operation**

**Fault diagnostics**



# FriWa



manual

**Thank you for buying a product.**

**Please read this manual carefully in order to put this controller to the best possible use.**

## Safety regulations:

Please read the following information carefully before installing and operating the controller. The mounting and the operation are to be carried out due to the accepted technical rules. Please pay attention to the Accident Prevention & Insurance Association regulation. RESOL will bear no liability for a wrong application or inadmissible changes during the mounting.

Attention should be paid to following technical rules:

DIN 4757, part 1

Solar heating systems with water and water mixtures as heat transfer medium; Demands to the safety realization

DIN 4757, part 2

Solar heating systems with organic heat transfer medium; Demands to safety realization.

DIN 4757, part 3

Solar heating systems; solar collectors; meanings; safety regulations; testing of standstill temperature

DIN 4757, part 4

Solar thermal systems; solar collectors; determination of efficiency, heat capacity and pressure loss.

In addition to that European standards are worked out:

EN 12975-1

Thermal solar systems and their components; collectors, part 1: General demands.

EN 12975-2

Thermal solar systems and their components; collectors; part 2: Test processes

EN 12976-1

Thermal solar systems and their components; prefabricated systems, part 1: General demands.

EN 12976-2

Thermal solar systems and their components; prefabricated systems, part 2: Test processes

EN 12977-1

Thermal solar systems and their components; Customer-designed manufactured systems, part 1: General demands.

EN 12977-2

Thermal solar systems and their components; Customer-designed manufactured systems, part 2: Test processes

EN 12977-3

Thermal solar systems and their components; Customer-designed manufactured systems, part 3: Performance test of hot water stores.

DIN 1988

Technical rules for the installation of drinking water.

DIN 4708

Central hot water warmer systems

DIN 4751

Water heating systems

DIN 4753

Water heater and hot water warmer systems for drinking and process water

DIN 18380

Heating and process water systems

DIN 18381

Gas, water und waste water installation workings DIN 18382  
electric conduct und circuit lines in buildings PrEN 12975  
Thermal solar systems and their components

VDE 0100

Installation of electric equipment

VDE 0185

General information on the installation of lightning protection

VDE 0190

Main potential equalization of electric system.

## Imprint:

This mounting and operation manual including all parts is copyrighted. Any use outside the copyright requires the approval of RESOL - Elektronische Regelungen GmbH. This especially applies for copies, translations, micro films and the storage into electronic systems.

Editor: RESOL - Elektronische Regelungen GmbH

## Important notice:

All descriptions and drawings contained in this manual have been prepared to the best of our knowledge and belief. The drawings in this manual are for the purpose of example and should be used at your own risk. We cannot be held responsible for any errors.

## Please note:

It is the responsibility of the installer to ensure current standards and industry best practices are followed.

Subject to change without notice. Errors excepted.

## Contents

Imprint .....	16	2	Operation and Functions.....	21
Technical Data .....	17	2.1	Setting pushbutton.....	21
1 Electrical Connection.....	18	2.2	Blinking codes .....	21
1.1 Overview of connections .....	18	3.	Functions and Options overview.....	22-23
1.2 Relay outputs .....	19	4.	Functions and Options .....	23-25
1.3 Sensors .....	19			
1.4 Data communication / Bus .....	19			
1.5 Electric supply.....	20			

- Protection against legionella bacteria
- Minimisation of heat losses
- Illuminated display
- Optional circulation for hot water supply without delay
- RESOLVBus®



### Technical data controller

**Housing:** plastic, PC-ABS and PMMA

**Protection category:**

IP 20 / DIN 40 050

**Ambient temp.:** 0 ... 40 °C

**Measurement:** 220 x 155 x 62 mm

**Operation:** via three pushbuttons

**Bus:** RESOLVBus®

**Supply:** 210 ... 250 V~

**Breaking capacity:** 4 (1) A 250V~

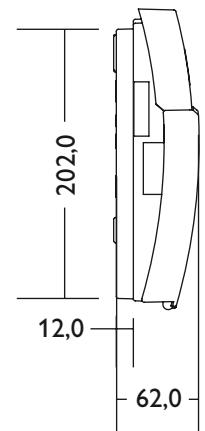
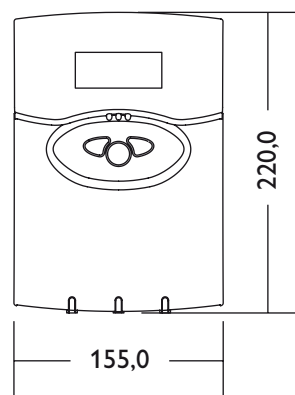

## 1. Electrical connection

The fresh water module is already wired. Points 2.1 - 2.5 are only for information.

The connection to the power supply system (230 V/AC, 50 - 60 Hz) is effected by the already clamped line connector. Workings on the current-carrying components of the FriWa-module must only be carried out by a specialist firm regarding current standards and corresponding norms (VDE 0100, VDE 0185, VDE 0190 etc.).

An appropriate grounding is carried out at the holding plate of the FriWa.



Electrostatical discharges can lead to damages of electronic components!



Please note: components are carrying high voltages!

### 1.1 Overview of the electrical connections

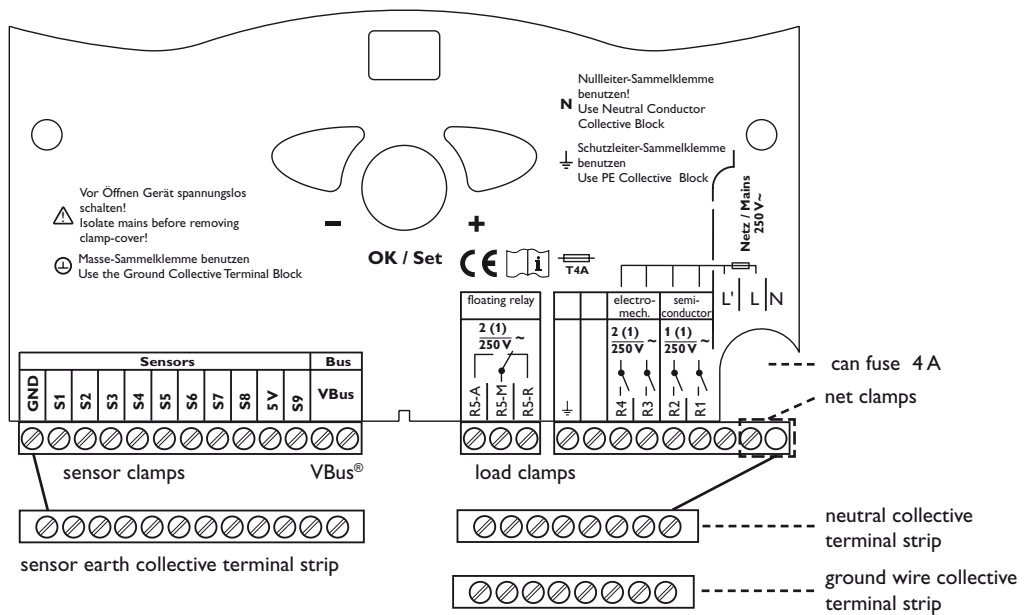

## 1.2 Relay outputs

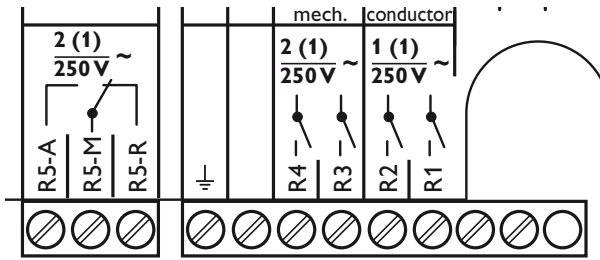

collective earth terminal strip



protection conductor collective terminal strip

The controller is equipped with a total of 5 relays to which loads (actuators) like valves and auxiliary relays are connected:

- The relays R1 und R2 are semiconductor relays and also suitable for a speed controller:  
 R1 ... R2 = normally open contact R1 ... R2  
 N = neutral contact (col. terminal strip)  
 PE = protection conductor PE (col.terminal strip)
- The relays R3 und R4 are electromechanical relays used for a normally open contact:  
 R3, R4 = normally open contact R3, R4  
 N = neutral contact relay N (col. terminal strip)  
 PE = protection conductor PE (col. terminal strip)
- Relay R5 is a floating relay with a change-over contact:  
 R5-M = medium power relay  
 R5-A = normally open contact relay  
 R5-R = break contact relay  
 N = neutral contact relay N (col. terminal strip)  
 PE = protection conductor PE (col. terminal strip)

R1	R2	R3	R4	R5
P1	Pc	VR	operating- / error relay	operating- / error relay

## 1.3 Sensors

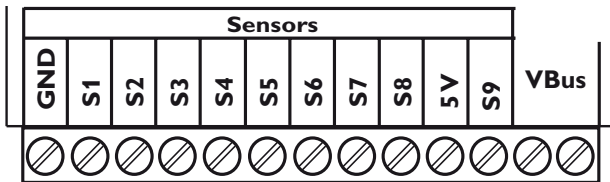

collective earth terminal strip

The controller is equipped with a total of 9 sensor inputs. The earth connection for sensors is effected via the sensor earth collective terminal strip (GND). The temperature sensors are to be connected with a user-defined polarity to clamps S1 ... S9 and GND.

The power supply of the sensors S7 and S8 is effected via clamp Us.

S1	S2	S3	S4	S5	S6
T-HW	T-Q	T-Sp	T-R	---	---

S7	S8	U <sub>s</sub>	S9
T-CW	dV	5V	on / off

## 1.4 Data communication / Bus

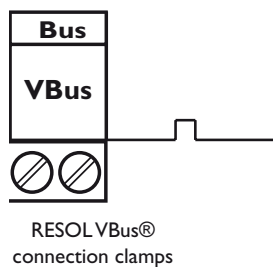

The controller disposes of a RESOL VBus® for data communication and the energy supply of external modules. The connection is carried out with a user-defined polarity at the „VBus“ labelled clamps.

## 1.5 Electric supply

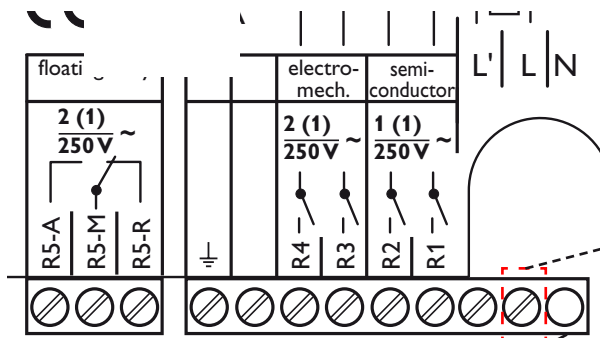

The electric supply of the controller has to be effected via an external power switch (last workstep!) and the supply voltage has to be 210... 250 Volt (50 ... 60 Hz). Flexible conductors are either to be fixed with the enclosed strain-relief clamps and the appropriate screws to the housing or to be induced in a cable conduit into the housing of the controller.

conductor L



neutral conductor N (collective terminal strip)



protective conductor PE (collective terminal strip)

- P1 Discharge pump
- Pc Circulation pump (optional)
- T-HW Sensor hot water temperature
- T-CW Sensor cold water temperature
- T-S Sensor heat source temperature
- dV Volume flow indicator

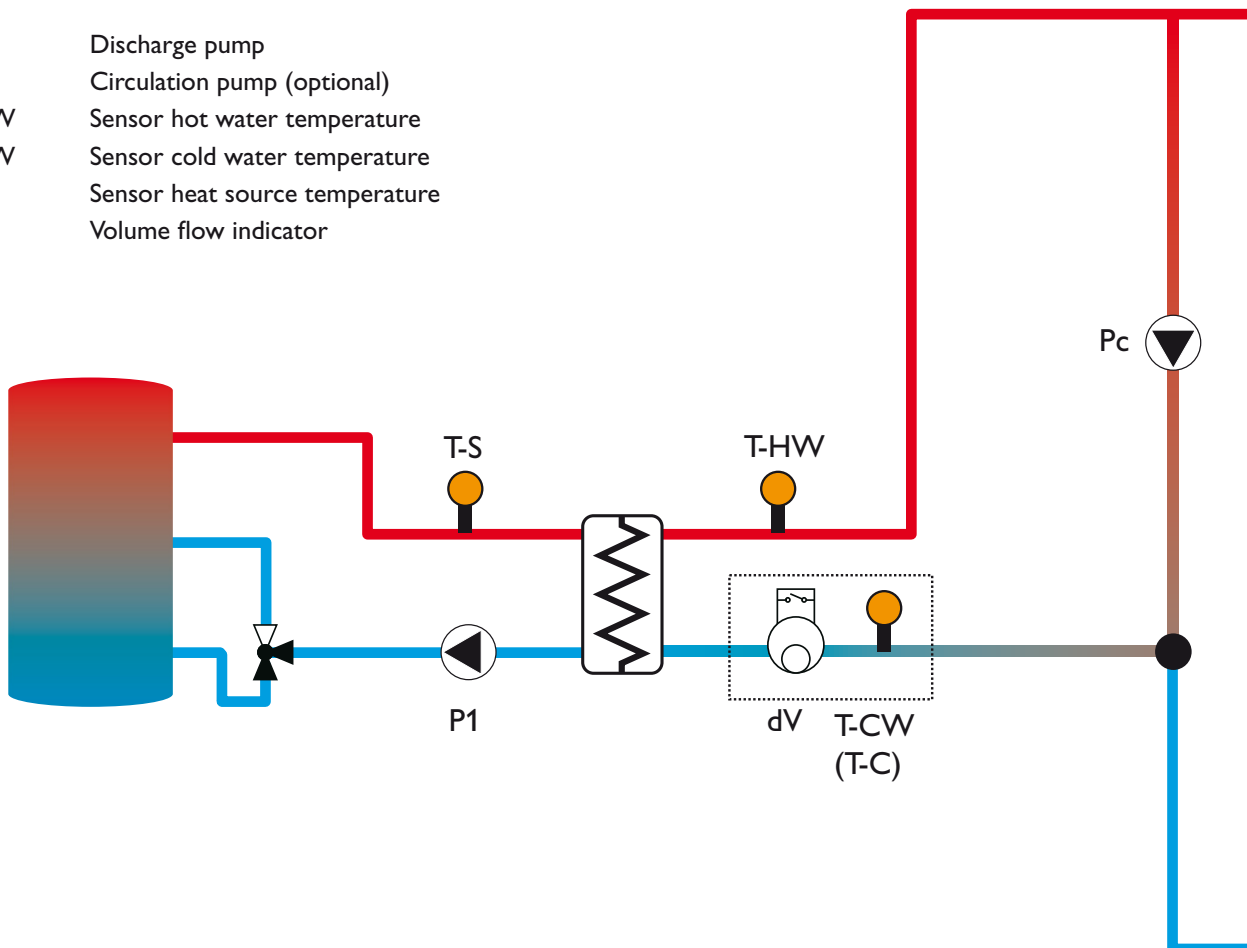

## 2. Operation and Function

### 2.1 Setting pushbutton

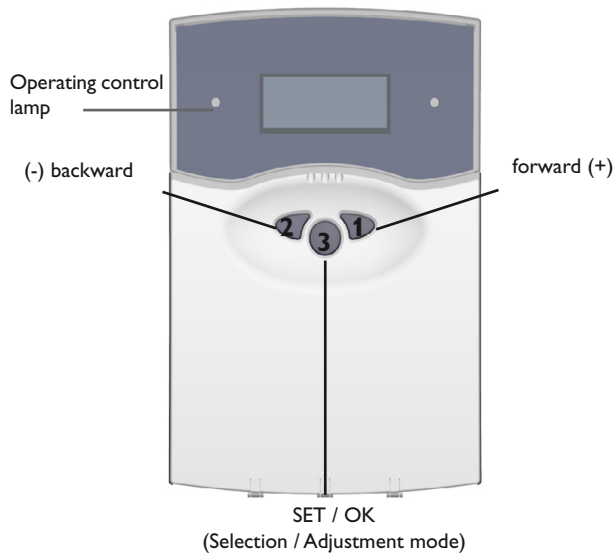

The controller is operated by three pushbuttons below the display. Button 1 is for scrolling forwards through the menu options or for increasing the adjustment values. Button 2 performs the opposite function.

Button 3 is for the adjustment of individual parameters. By pressing button 3 you will get to the next submenu or the SET-mode. It is also used for the confirmation of the adjustments made.

In order to get to the main menu the backward button has to be set to „back“ and has to be confirmed with the SET/OK button. If no button has been pressed for more than 60 seconds, the controller is automatically set back to the main menu.

**Important notice:** The selectable values and options are function-dependant and will only appear on the display if they are available for the adjusted start parameter and activated via the operation code.

**Operator code:** Expert-Code 119

The expert menu is accessible after entering the operator code, here the values can be changed.

### 2.2 Blinking codes

Constantly green:  
Blinking red/green:  
Blinking green:  
Blinking red:

orderly operation  
initialisation phase (10 sec.)  
manual operation  
sensor failure

Main menu:
Meas. values
Reports
Balances
Settings
Options
Manual operation
User code
Expert

Meas. values:
back
T-HW
T-S
T-St
T-R
T-CW
T-C
Tap
Time
Load. pump
Circulation
Return valve
Relays 1-5
Sensors 1-9

Reports:
back
Everything OK
Initialization
!Sensor failure
>>Meas. values
!EEPROM
!RTC
-Manual operat.
-Circulation
-Emergency oper.
-Block. protect.
-External of
-Return divert.
-Hot water gen.
SW-Version

Balances:
back
Operation
Volume
Vol. max
Load. -p.
Circ.-p.
T-S min
T-S max
T-CW mn
T-CW mx
Heat qty (Wh)
Heat qty (kWh)
Heat qty (MWh)

Settings:
back
Hotwater
BP on
BP off
BP wait
Circ.run
Circ.wait
Circ.sensor
Circ.hyst.
Circ.min
Week timer circ.
ΔT-Rd on
ΔT-Rd off.
Emergency
Time
Language

Options:
back
Circulat.
Return div.
Error rel.
Signal rel.
Extern Off
Emergency

Manual operation
back
Relay 1-5

Expert:
back
BP time
Tap min.
Rot. min.
Default settings
Algorithm

### 3. Functions and Options overview

Description	Menu code	Type	Range	Factory setting
Temperature hot water	<i>T-HW</i>	M	-50,0 ... 250,0 °C	-----
Temperature cold water	<i>T-CW</i>	M	-50,0 ... 250,0 °C	-----
Temperature heat source	<i>T-S</i>	M	-50,0 ... 250,0 °C	-----
Temperature return flow	<i>T-R</i>	M	-50,0 ... 250,0 °C	-----
Temperature store	<i>T-ST</i>	M	-50,0 ... 250,0 °C	-----
Temperature circulation	<i>T-CIRC.</i>	M	-50,0 ... 250,0 °C	-----
Volume flow	<i>TAP</i>	M	0 ... 9999 l/h	-----
Rot.speed loading pump	<i>LOAD. PUMP</i>	S	Off / 0 ... 100 %	-----
Status circulation pump	<i>CIRCULATION</i>	S	Off ... On	-----
Status return flow dispersion	<i>RETURN VALVE</i>	S	Off ... On	-----
Operational mode load pump	<i>RELAY 1</i>	P	On / Auto / Off	Auto
Operational mode Circ.-pump	<i>RELAY 2</i>	P	On / Auto / Off	Auto
Op. mode return flow valve	<i>RELAY 3</i>	P	On / Auto / Off	Auto
Status manual operation function	<i>MANUAL OPERATION</i>	S	On / Auto / Off	-----
Circulation run time	<i>CIRC.RUN</i>	P	1 min. ... 10 min.	2 min.
Circulation off-time	<i>CIRC.WAIT</i>	P	0 min. ... 20 min.	10 min.
Heat up hysteresis circulation	<i>CIRC.HYST</i>	P	0,5 ... 10 K	5,0 K
Minimum temperature circulation	<i>CIRC.MIN</i>	P	10 ... 60 °C	40 °C
Circulation week timer	<i>WEEK TIMER CIRC.</i>	P		
Option Circulation	<i>CIRCULAT.</i>	P	No/Demand/Therm.	No
Status circulation function	<i>-CIRCULATION</i>	S	On ... Off	-----
Option return flow partition	<i>RETURN DIV.</i>	P	Yes ... No	No
Switch-on differential return valve	<i>ΔT-RD ON</i>	P	0,0 ... 25,0 K	5,0
Switch-off differential return valve	<i>ΔT-RD OFF</i>	P	0,0 ... 25,0 K	3,0
Option error relay	<i>ERROR REL.</i>	P	No ... R4/R5	No
Option operation relay	<i>SIGNAL REL.</i>	P	No ... R4/R5	No
Option external off	<i>EXTERN OFF</i>	P	Yes ... No	No
Status function hot water gen..	<i>-HOT WATER GEN.</i>	S	On ... Off	-----
Operating days regulation	<i>OPERATION</i>	B	0 ... 99999 Days.	0
Tap quantity	<i>VOLUME</i>	B	0,0 ... 9999,9 m3	0,0
Major volume flow	<i>VOL. MAX</i>	B	0 ... 9999 l/h	0
Operating hours loading pump	<i>LOAD.-P.</i>	B	0 ... 99999 h	0
Operating hours circ. pump	<i>CIRC.-P.</i>	B	0 ... 99999 h	0
Minimum temperature source	<i>T-S MIN</i>	B	-50,0 ... 250,0 °C	250,0 °C
Maximum temperature source	<i>T-S MAX</i>	B	-50,0 ... 250,0 °C	-50,0 °C
Minimum temperature cold water	<i>T-CW MIN</i>	B	-50,0 ... 250,0 °C	250,0 °C
Maximum temperature cold water	<i>T-CW MAX</i>	B	-50,0 ... 250,0 °C	-50,0 °C
Heat quantity	<i>HEAT QTY</i>	B	0 ... 999	Wh/kWh/MWh
Option emergency service	<i>EMERGENCY</i>	P	Yes ... No	No
Emergency operation level	<i>EMERGENCY</i>	P	12 ... 100 %	100 %
Status emergency operation	<i>-EMERGENCY OPERAT.</i>	S	see right	-----
Error reports	<i>!SENSOR FAILURE</i>	S	see right	

Description	Menu code	Type	Range	Factory Setting
Preset temperature hotwater	<i>HOT WATER</i>	P	45 ... 65 °C	55 °C
Block protection acceleration time	<i>BP ON</i>	P	00:00-23:59	06:00
Block protection end time	<i>BP OFF</i>	P	00:00-23:59	20:00
Block protection tap wait time	<i>BP WAIT</i>	P	30 min ... 6 h	4 h
Status function blocking protection	<i>-BLOCK. PROTECT.</i>	S		
Time blocking protection	<i>BP TIME</i>	P	1 s ... 10 s	4 s
Minimum rotational speed	<i>ROT. MIN.</i>	P	12 % ...100 %	12 %
Pump start impulse	<i>START IMP.</i>	P	1 s ... 5 s	1 s
Tap identification	<i>TAP MIN.</i>	P	30 l/h .. 300 l/h	90 l/h
Maximum volume flow	<i>MX. FLOW</i>	P	0 l/h ... 9999 l/h	1550 l/h
Hysteresis preset value exceedence	<i>ΔT-CONTR.-MIN.</i>	P	0 K ... 10 K	5 K
Hysteresis preset value underrun	<i>ΔT-CONTR.-ON</i>	P	0 K ... 25 K	-5 K
Week timer	<i>TIME</i>	P	Mo. 00:00 ... Su. 23:59	Su 12:00
Factory setting	<i>FACTORY SETTING</i>	P	Yes ... No	No

## Typen:

Parameter	P
Balance values	B
Meas. values	M
Status value	S
Constants	K

## 4. Functions and Options

### 4.1 Circulation (demand version)

*OPTIONS/CIRCULAT.*

Adjustment range No, demand, therm

Factory setting No

*SETTINGS/CIRC.RUN*

Adjustment range 1 - 10 min

Factory setting 2 min

*SETTINGS/CIRC.WAIT*

Adjustment range 00:00 - 00:20 min

Factory setting 00:10 min

A short impulse starts the circulation pump.

The pump is started up for an adjusted time span (circulation run time). When the run time is over, the restart demand for the circulation will be blocked for a set time span (circulation holding time). The active function is displayed.

### 4.2 Circulation (thermal version)

*OPTIONS/CIRCULAT.*

Adjustment range No, demand, therm.

Factory setting No

*SETTINGS/WEEK TIMER CIRC.*

(only visible when thermal circulation is activated )

Adjustment range t1 - t21 on / off

The temperature of the hot water line will be checked within a specified time frame (week timer (WT)) and with the help of sensor T-C. If the pre-adjusted minimum temperature is underrun (Circ.min), the circulation pump will be started up. It will be shut off again after the hot water line has been heated up by the adjusted heat hysteresis. The sensor T-C can either be connected to sensor S5, S6 or S7 (T-CW) (factory setting S7).

The minimum circulation temperature (Circ.min) is linked to the hot water temperature and the circulation hysteresis and will be automatically adjusted.

The active function is displayed.

## 4.3 Hot water processing

SETTINGS/HOTWATER

Adjustment range 45 ... 65°C

Factory setting 55°C

As a result of the tap signal (dV) the load circulation is started and the fresh water is heated up to the adjusted temperature.

The active function is displayed.

## 4.4 Return flow dispersion

OPTIONS/RETURN FLOW

Adjustment range off ... on

Factory setting ---

SETTINGS/ $\Delta T$ -RD ON

Adjustment range 0,0 ... 25,0 K

Factory Setting 5,0 K

SETTINGS/ $\Delta T$ -RD OFF

SETTINGS 0,0 ... 25,0 K

Factory setting 3,0 K

If the measured differential between the return flow temperature (T-R) and the store referential temperature (T-St) exceeds the adjusted temperature ( $\Delta T$ -RD ON) relay V-R will be switched on.

It will be switched off again if the load circuit is not in operation or the adjusted switch-off differential ( $\Delta T$ -RD OFF) is underrun.

## 4.5 Blocking protection

SETTINGS/BP ON

Adjustment range 00:00 ... 23.59

Factory setting 6:00

SETTINGS/BP OFF

Adjustment range 00:00 ... 23.59

Factory setting 20:00

SETTINGS/BP WAIT

Adjustment range 00:00 ... 23.59

Factory setting 4:00

In order to secure a proper start up of the pumps with lower pump levels as well as the pumps with longer tap pauses it is necessary to activate the pump regularly, e.g. every four hours (during the day [6:00 a.m. to 8 p.m.] and only if the tapping wasn't done in the meantime).

The active function is displayed.

## 4.6 Error relay

OPTIONS/ERROR REL.

Adjustment range No ... R4/5

Factory setting No

If there is a sensor or a controller error, the error relay will drop out. The relay for the error report can be adjusted (R4 and/or R5). This function can be used for an additional external display.

## 4.7 Operation report

OPTIONS/SIGNAL.REL.

Adjustment range No ... R4/5

Factory setting No

If the primary circuit is set up (processing of drinking water), the relay is switched on. The relays for the operation indication can be adjusted (R4 and/or R5).

This function can be used for an additional external display.

## 4.8 Error report

REPORTS

Defective sensors are displayed.

## 4.9 Balance value

*BALANCES*

Following values are balanced:

- operating days regulation
- tap quantity (cold water supply)
- major volume flow
- operating hours loading pump (P1)
- operating hours circulation pump (PC)
- minimum temperature of the source (T-S)
- maximum temperature of the source (T-S)
- minimum temperature cold water (T-CW)
- maximum temperature cold water (T-CW)
- intergrated energy in hot water circuit  
(see heat quantity)

## 4.10 Emergency operation

*OPTIONS/EMERGENCY*

Adjustment range Yes ... No

Factory setting No

Due to this option the pump can be set to a fixed pump level in continuous operation.

*SETTINGS/EMERGENCY*

Adjustment range 12...100%

Factory setting 100%

The pump speed during emergency service can be adjusted.

## 4.11 Manual operation

*MANUAL OPERATION*

Adjustment range Off, Auto, On

Factory Setting Auto

Each relay can be switched off and on by means of manual operation.

## 4.12 Switching off the controller externally

*OPTIONS/EXTERN OFF*

Adjustment range Yes ... No

Factory setting No

By means of input S9 the controller can be switched off. This means that the fresh water processing, circulation function, blocking protection, emergency service and return flow will be suppressed. The manual operation mode at the controller will flout the external control signal.

## 4.13 Energy quantity (heat quantity)

*BALANCES*

By means of the measured volume flow, the domestic cold and hot water and hot temperature the energy quantity can be measured.

## Notes

Notes

Notes

Notes

