

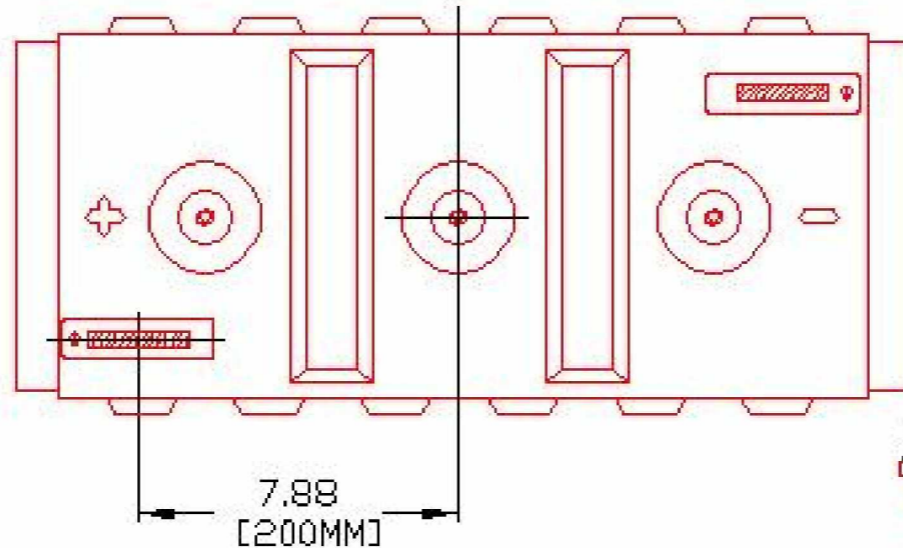

HEAVY DUTY DEEP CYCLE SERIES 5000

BATTERY TYPE	VOLTS	6	6 CS 21P
DIMENSIONS			
LENGTH		559 MM	22 INCHES
WIDTH		248 MM	9 3/4 INCHES
HEIGHT		464 MM	18 1/4 INCHES
WEIGHT DRY		99 KG	217 LBS.
WEIGHT WET		123 KG	271 LBS.
CONTAINER CONSTRUCTION			
INNER CONTAINER		POLYPROPYLENE	
INNER COVER		POLYPROPYLENE - HEAT SEALED TO INNER CONTAINER	
OUTER CONTAINER		HIGH DENSITY POLYETHYLENE	
OUTER COVER		HIGH DENSITY POLYETHYLENE SNAP FIT TO OUTER CONTAINER	
HANDLES		MOLDED	
PLATES PER CELL		21	
ELECTROLYTE RESERVE	ABOVE PLATES	95 MM	3.75 INCHES
DESIGN CRITERIA	10 YEAR WARRANTY	3300 CYCLES	15 YEAR LIFE
POSITIVE PLATE DIMENSION			
HEIGHT		273 MM	10.750 INCHES
WIDTH		143 MM	5.625 INCHES
THICKNESS		6.73 MM	0.265 INCHES
NEGATIVE PLATE DIMENSION			
HEIGHT		273 MM	10.750 INCHES
WIDTH		143 MM	5.625 INCHES
THICKNESS		4.70 MM	0.185 INCHES
SEPARATOR	SEPARATOR THICKNESS	0.105 INCH	
INSULATION	POSITIVE PLATE ENVELOPED BY VERTICAL SLYVER GLASS MAT		
TERMINALS	FLAG WITH STAINLESS STEEL NUTS AND BOLTS		
COLD CRANK	CCA	0°F / -17.8°C	1740
	MCA	32°F / 0°C	2175
	RESERVE		1353
	MINUTES AT 25A		
CAPACITY	20 HR RATE	683	
		CAP / AH	CURRENT / AMPS
CAPACITY AT THE 20 HOUR RATE	1.265 SP. GR.	683	34.2
CAPACITY AT THE 15 HOUR RATE	1.265 SP. GR.	642	42.8
CAPACITY AT THE 12 HOUR RATE	1.265 SP. GR.	608	50.7
CAPACITY AT THE 10 HOUR RATE	1.265 SP. GR.	581	58.1
CAPACITY AT THE 8 HOUR RATE	1.265 SP. GR.	546	68.3
CAPACITY AT THE 6 HOUR RATE	1.265 SP. GR.	505	84.2
CAPACITY AT THE 5 HOUR RATE	1.265 SP. GR.	478	96
CAPACITY AT THE 4 HOUR RATE	1.265 SP. GR.	444	111
CAPACITY AT THE 3 HOUR RATE	1.265 SP. GR.	403	134
CAPACITY AT THE 2 HOUR RATE	1.265 SP. GR.	348	174
CAPACITY AT THE 1 HOUR RATE	1.265 SP. GR.	246	246



PART NUMBER: 6-CS-21P
 WEIGHT WET: 271 LB / 123 KG
 WEIGHT DRY: 217 LB / 98 KG
 CAPACITY: 683 AH 20 HR
 963 AH 100 HR
 VOLTAGE: 6 V
 OVERALL DIMENSIONS: 22X9 3/4X18 1/4"

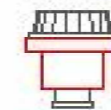

MAX HEIGHT WITH OPTIONAL HYDROCAPS: 18 5/8" - 473 MM

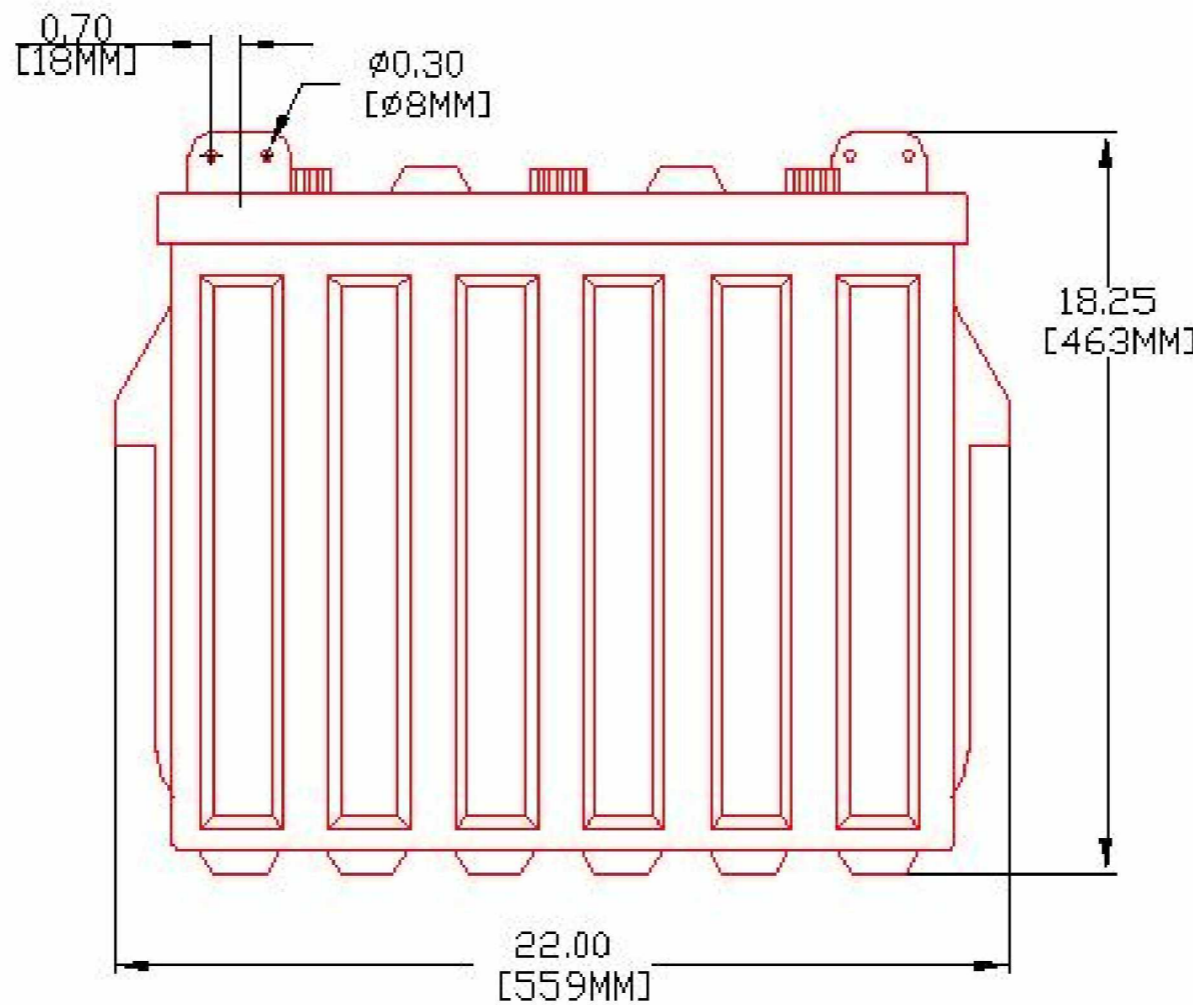
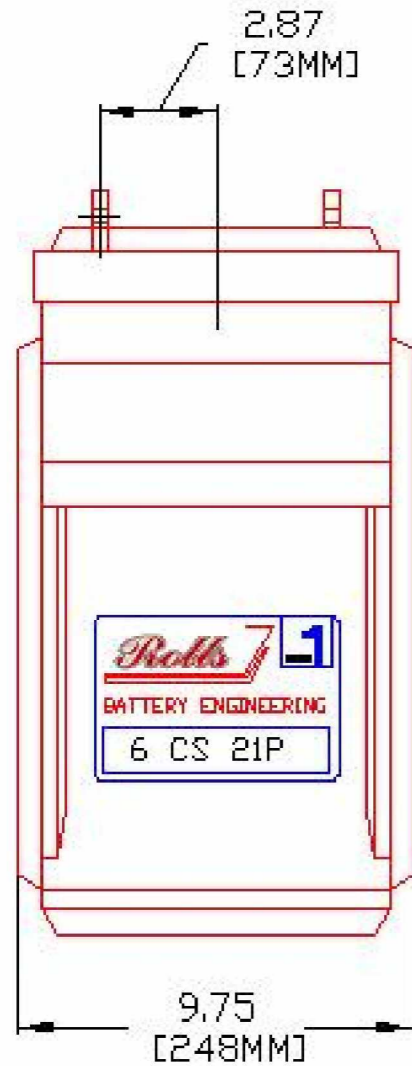

BATTERY ENGINEERING SALEM, MASS

TITLE: 6CS21P

DESCRIPTION: 6V / 2 CELL 21 PLATE (CS) DEEP CYCLE 500/5000 SERIES

CONTACT INFO:
 WEB: WWW.ROLLSBATTERY.COM
 E-MAIL: SALES@ROLLSBATTERY.COM
 PHONE: 1-800-681-9914

SCALE: 1" = 6" 1" = 4" JPEG
 8.5" X 11" 11" X 17" NOT TO SCALE

Drawn by: S. WILES Approved By: D. SURRETTE

DATE: 14-JUN-00 REVISION: 2.1

DRAWING NO.: DWG 006, BD6CS21P